



VHLP3-26/A

1.0 m | 3 ft ValuLine® High Performance Low Profile Antenna, single-polarized, 24.250–26.500 GHz

General Specifications

| | |
|-------------------|---|
| Antenna Type | VHLP - ValuLine® High Performance Low Profile Antenna, single-polarized |
| Diameter, nominal | 1.0 m 3 ft |
| Polarization | Single |

Electrical Specifications

| | |
|--|---|
| Beamwidth, Horizontal | 0.9 ° |
| Beamwidth, Vertical | 0.9 ° |
| Cross Polarization Discrimination (XPD) | 30 dB |
| Electrical Compliance | Brazil Anatel Class 2 ETSI 302 217 Class 3 US FCC Part 101A |
| Front-to-Back Ratio | 72 dB |
| Gain, Low Band | 45.6 dBi |
| Gain, Mid Band | 45.8 dBi |
| Gain, Top Band | 46.2 dBi |
| Operating Frequency Band | 24.250 – 26.500 GHz |
| Radiation Pattern Envelope Reference (RPE) | 7156A |
| Return Loss | 17.7 dB |
| VSWR | 1.30 |

Mechanical Specifications

| | |
|-------------------------------|------------------------------|
| Fine Azimuth Adjustment | ±15° |
| Fine Elevation Adjustment | ±15° |
| Mounting Pipe Diameter | 90 mm–120 mm 3.5 in–4.7 in |
| Net Weight | 17 kg 37 lb |
| Side Struts, Included | 0 |
| Side Struts, Optional | 1 inboard |
| Wind Velocity Operational | 200 km/h 124 mph |
| Wind Velocity Survival Rating | 250 km/h 155 mph |

Wind Forces At Wind Velocity Survival Rating

| | |
|---------------------------------------|------------------|
| Angle α for MT Max | 0 ° |
| Axial Force (FA) | 2903 N 653 lbf |
| Side Force (FS) | 1439 N 324 lbf |
| Twisting Moment (MT) | 1179 N•m |
| Weight with 1/2 in (12 mm) Radial Ice | 46 kg 101 lb |
| Zcg with 1/2 in (12 mm) Radial Ice | 84 mm 3 in |
| Zcg without Ice | 135 mm 5 in |

VHLP3-26/A

POWERED BY



Wind Forces At Wind Velocity Survival Rating Image

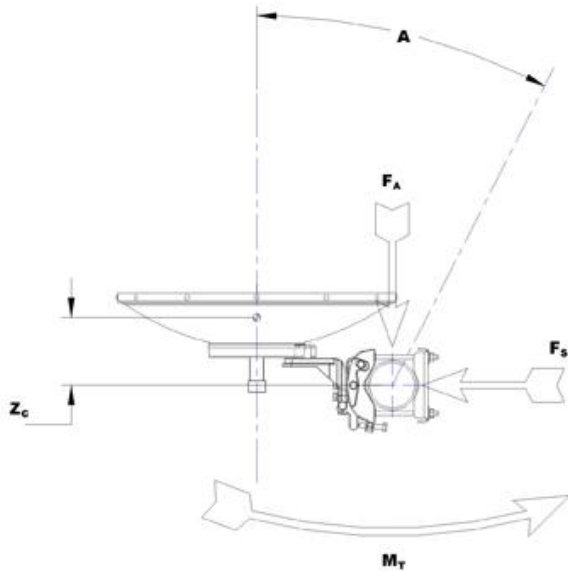

VHLP3-26/A

POWERED BY



Antenna Dimensions And Mounting Information

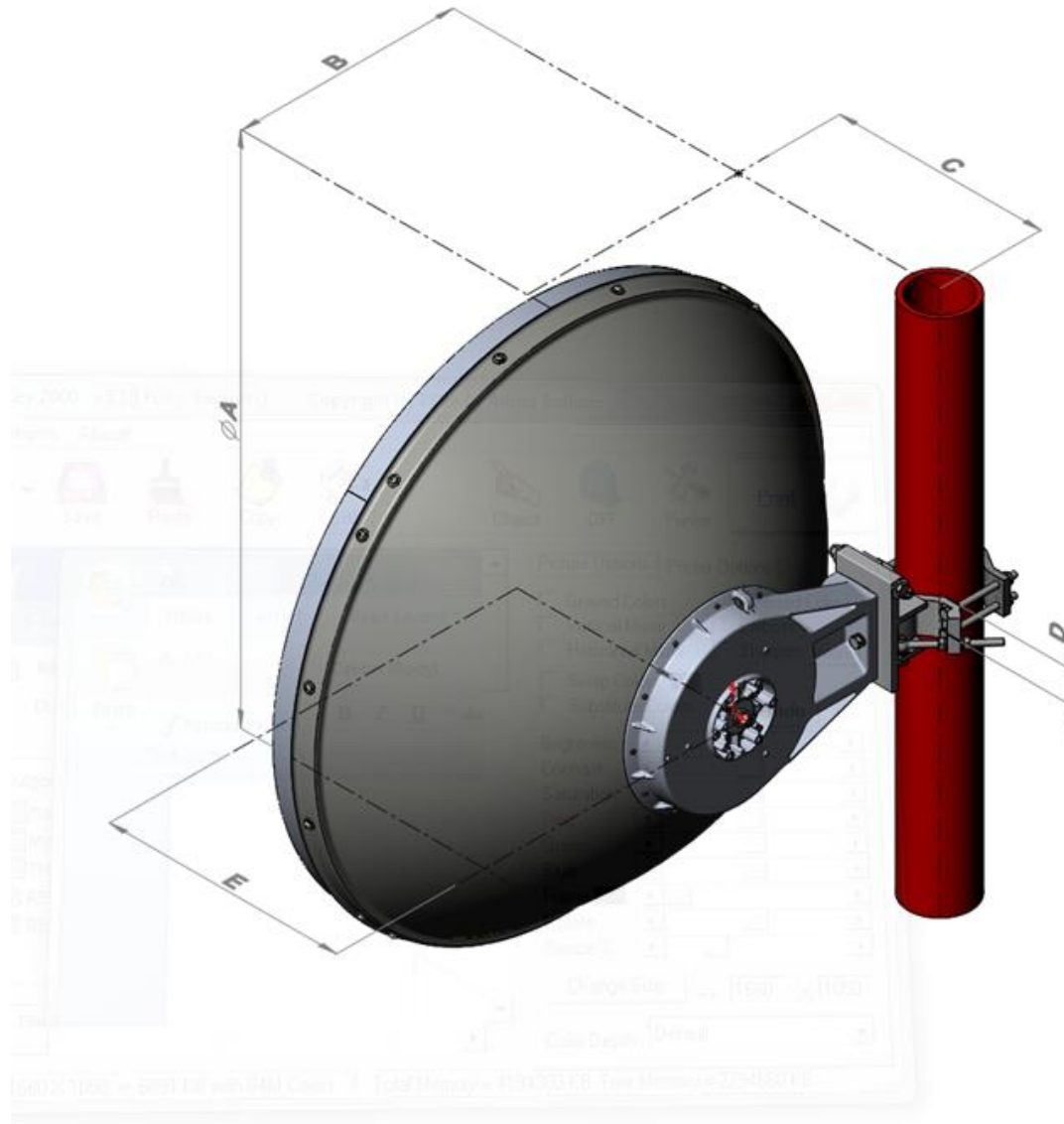

| Dimension in Inches (mm) | | | | | |
|--------------------------|------------|----------|------------|----------|------------|
| Antenna size, ft (m) | A | B | C | D | E |
| 3 (1.0) | 39.3 (999) | 16 (407) | 15.2 (387) | 2.4 (60) | 17.2 (437) |

* Footnotes

Axial Force (FA)

Maximum forces exerted on a supporting structure as a result of wind from the most critical direction for this parameter. The individual maximums specified may not occur simultaneously. All forces are referenced to the mounting pipe.

Cross Polarization Discrimination (XPD)

The difference between the peak of the co-polarized main beam and the maximum

VHLP3-26/A

POWERED BY



| | |
|--|--|
| | cross-polarized signal over an angle twice the 3 dB beamwidth of the co-polarized main beam. |
| Front-to-Back Ratio | Denotes highest radiation relative to the main beam, at $180^\circ \pm 40^\circ$, across the band. Production antennas do not exceed rated values by more than 2 dB unless stated otherwise. |
| Gain, Mid Band | For a given frequency band, gain is primarily a function of antenna size. The gain of Andrew antennas is determined by either gain by comparison or by computer integration of the measured antenna patterns. |
| Operating Frequency Band | Bands correspond with CCIR recommendations or common allocations used throughout the world. Other ranges can be accommodated on special order. |
| Radiation Pattern Envelope Reference (RPE) | Radiation patterns determine an antenna's ability to discriminate against unwanted signals under conditions of radio congestion. Radiation patterns are dependent on antenna series, size, and frequency. |
| Return Loss | The figure that indicates the proportion of radio waves incident upon the antenna that are rejected as a ratio of those that are accepted. |
| Side Force (FS) | Maximum side force exerted on the mounting pipe as a result of wind from the most critical direction for this parameter. The individual maximums specified may not occur simultaneously. All forces are referenced to the mounting pipe. |
| Twisting Moment (MT) | Maximum forces exerted on a supporting structure as a result of wind from the most critical direction for this parameter. The individual maximums specified may not occur simultaneously. All forces are referenced to the mounting pipe. |
| VSWR | Maximum; is the guaranteed Peak Voltage-Standing-Wave-Ratio within the operating band. |
| Wind Velocity Operational | The wind speed where the antenna deflection is equal to or less than 0.1 degrees. In the case of ValuLine antennas, it is defined as a maximum deflection of 0.3 x the 3 dB beam width of the antenna. |
| Wind Velocity Survival Rating | The maximum wind speed the antenna, including mounts and radomes, where applicable, will withstand without permanent deformation. Realignment may be required. This wind speed is applicable to antenna with the specified amount of radial ice. |